

Oxbot Champ Racing Stack

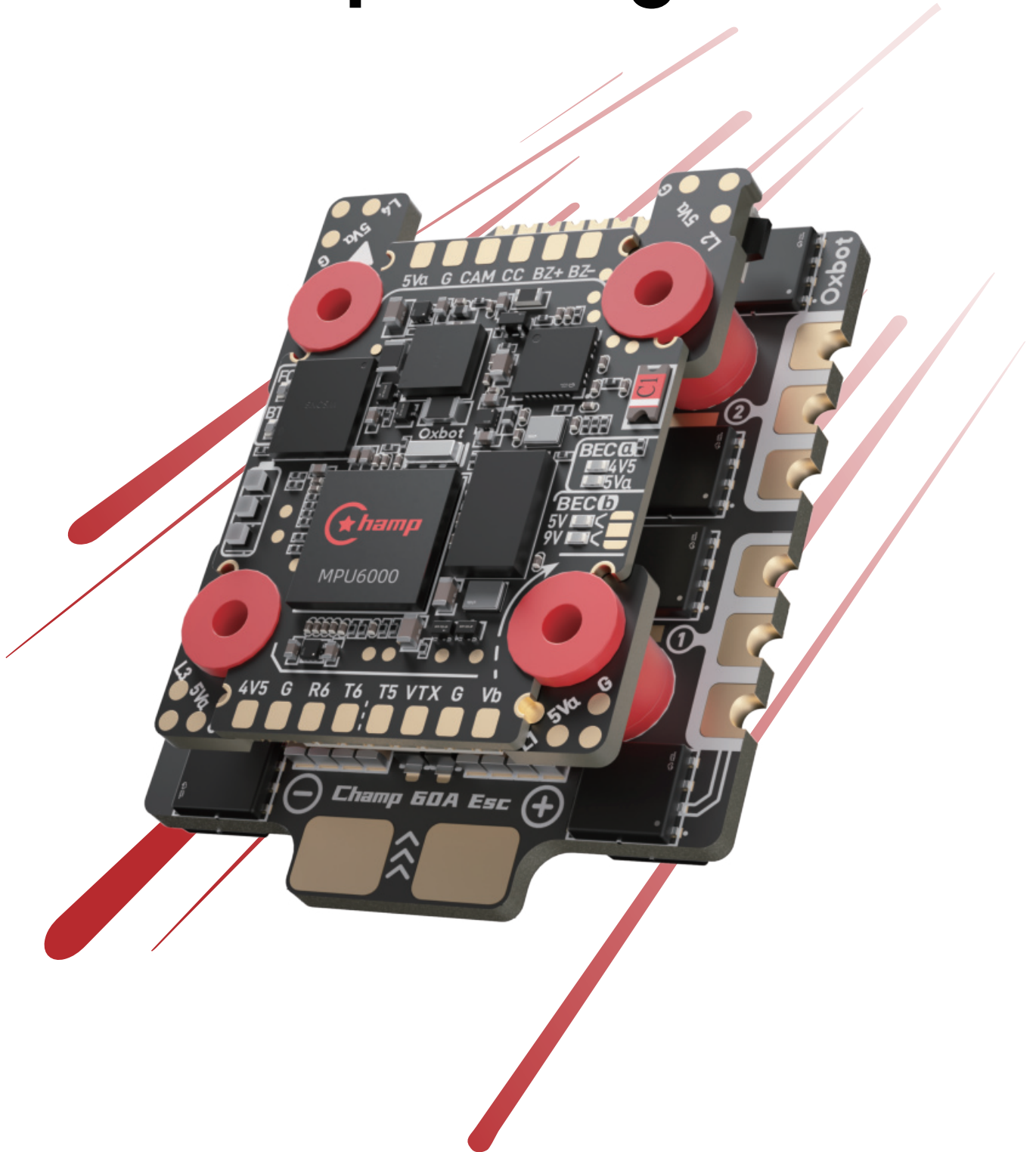

User Manual

Contents

Part 1 / Overview

1. Specs Overview	1
2. Dimensions	1
3. Stack Installation	2
4. FC-ESC Connection	3
5. Package	4-5
5.1 Stack	
5.2 FC Only	
5.3 ESC Only	

Part 2 / Flight Controller

1. Layout	6-7
2. Peripheral Connections	8-18
2.1 Connection Overview	
2.2 Connection Details	
2.2.1 LED Strip	
2.2.2 Receiver	
2.2.3 VTX	
2.2.4 Camera	
3. APP Connection	18
4. Firmware Update	19-21
5. Specifications	22-23

Part 3 / ESC

1. Layout	24
2. FC & Motor Connection	25
3. Configuration Instructions	26-27
3.1 Connect to Ground Station and Configure	
3.2 ESC Firmware Update	
4. Specifications	27

Part 1/ Overview

1. Specs Overview

Product Name	Oxbot Champ Racing Stack
Flight Controller (FC) MCU	STM32H743
Electronic Speed Controller (ESC) MCU	ATF421
FC Firmware	Betaflight
ESC Firmware	OX32
FC	Oxbot Champ Racing FC
ESC	Oxbot Champ 60A OX32 4-in-1 Racing ESC
Bluetooth	Supported, for FC Tuning.
Wireless FC Firmware Flashing	Supported.
ESC Firmware Configurator	https://ox32.oxbot.com
Power Input	3~8S
Mounting Holes	20 x 20mm, M3
Dimensions	FC: 34.9mm (L) x 27mm (W) x 5.1mm (H) ESC: 42.7mm (L) x 35mm (W) x 4.7mm (H)
Weight	21.3g
Full Manual Download	https://oxbot.com/download-oxbot-champ-racings-stack/

2. Dimensions

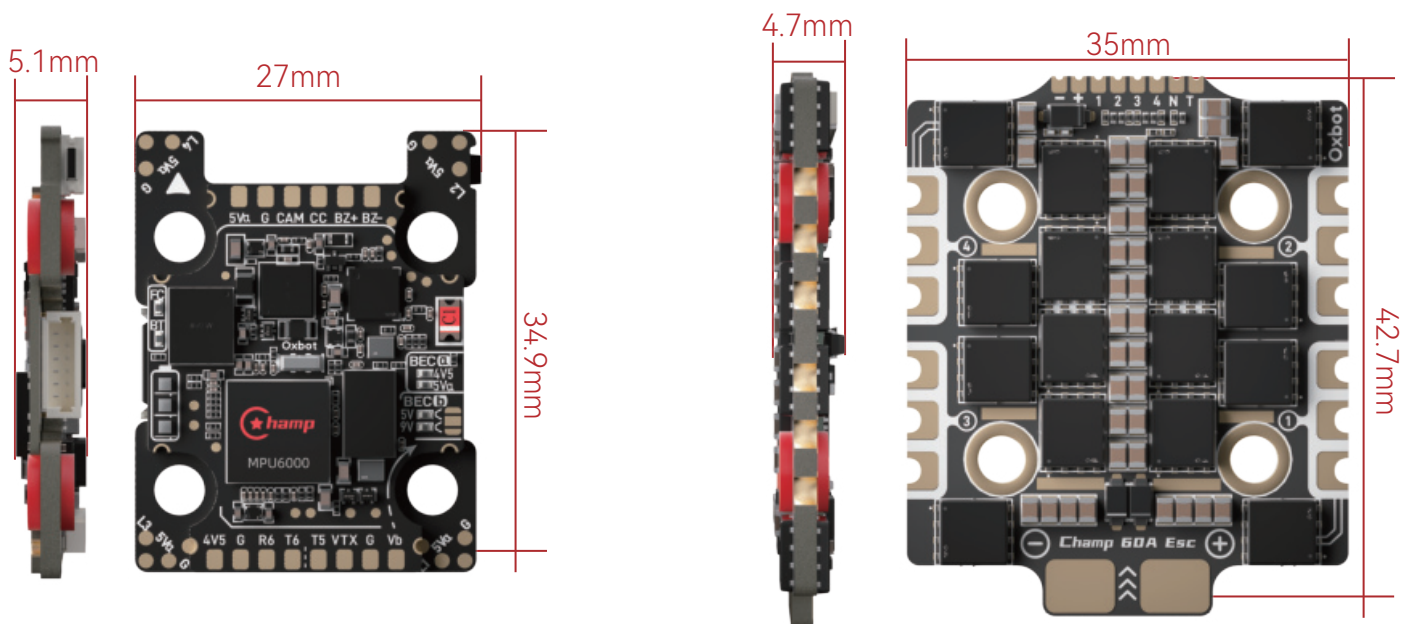

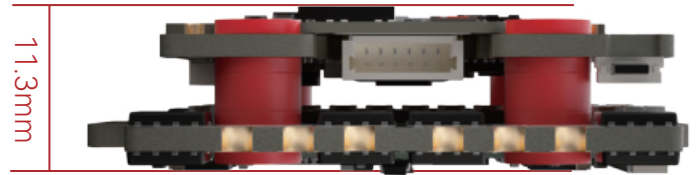
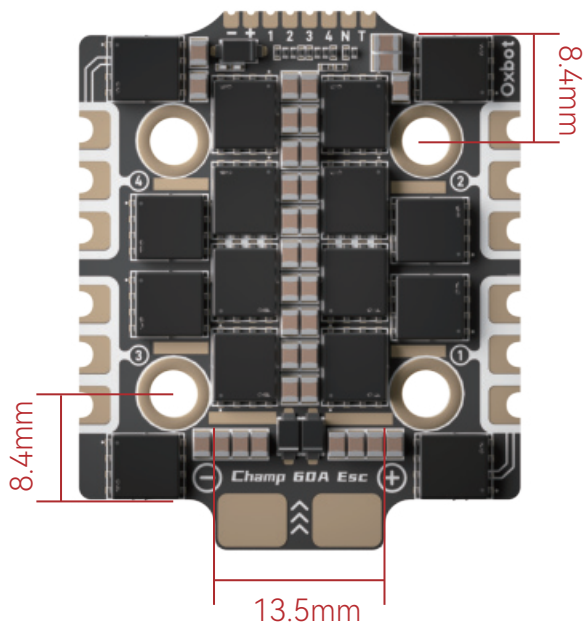

3. Stack Installation

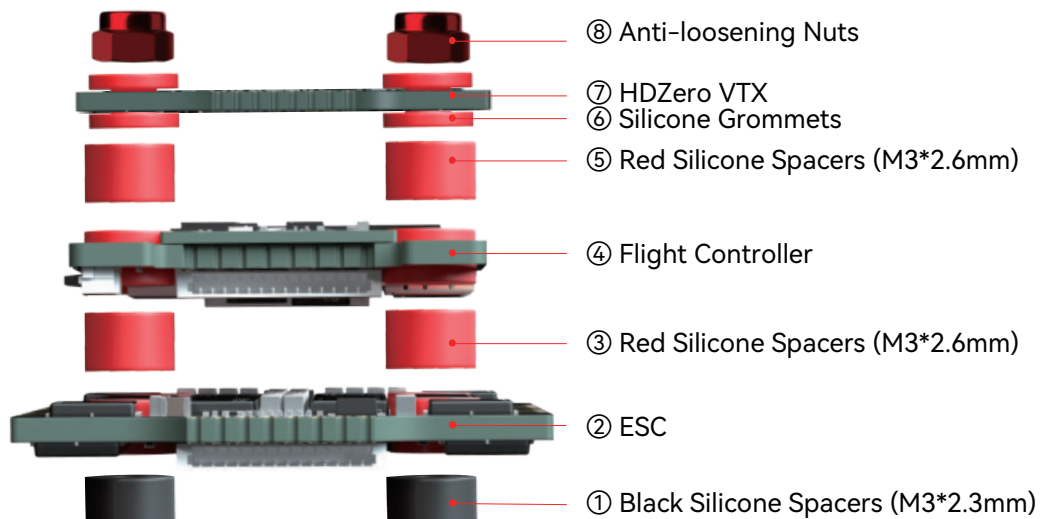

Key Tips:

- Replace the original HDZero VTX **Silicone Grommets** with the provided ones (as shown in ⑥) and use the included 21mm aluminum standoffs to reduce frame height and enhance flight performance.
- Please install the **Silicone Spacers** strictly as shown above. Improper installation may cause contact between the stack, VTX, and frame, resulting in damage.

4. FC-ESC Connection

Use the included 14P cable to connect the FC and ESC; or directly solder the 8 wires to the 8 pads on both ends.

Method 1: Direct Plug-in Using 14-pin Cable

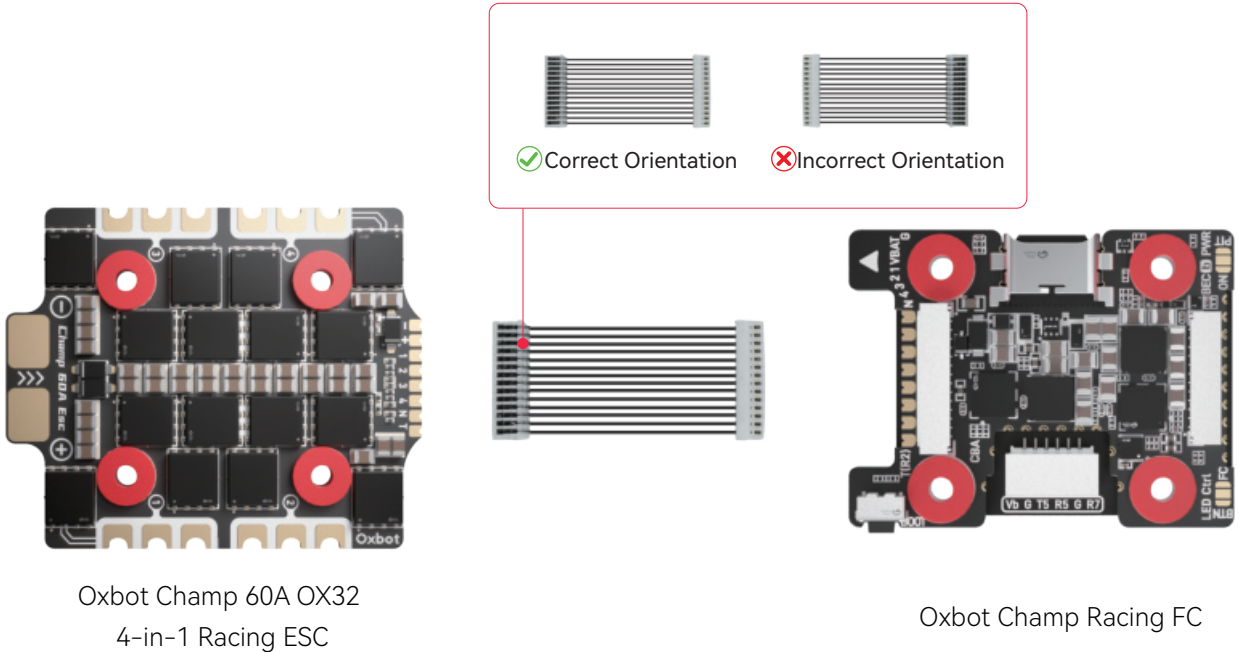

Method 2: Soldering Wires

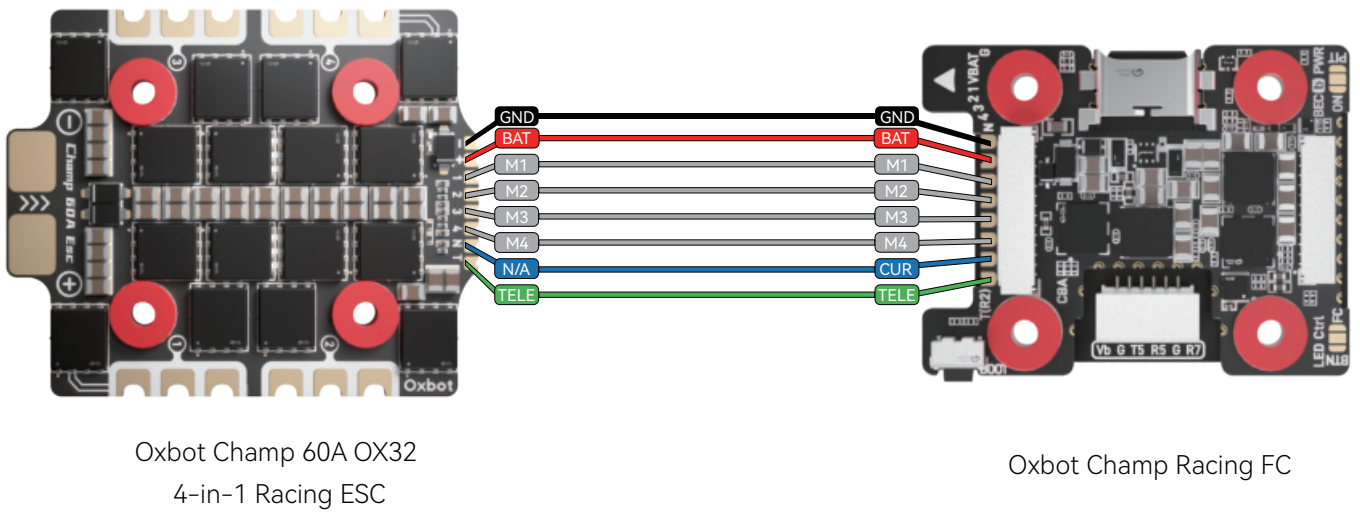

5. Package

5.1 Stack



Oxbot Champ Racing FC
(MPU6000 Version / ICM42688 Version) x1

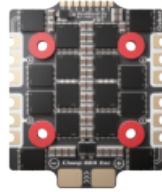

Oxbot Champ
60A OX32 4-in-1 Racing ESC x1

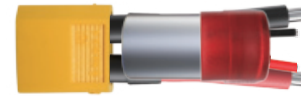

Anti-broken Soft-legged
Capacitor Set x1



Black Heat Shrink Tubes 10mm x2
12AWG Spare Power Cables 70mm x2



14P Cable 20mm x1
(for connecting FC and ESC)



6P SH1.0 Cable 15mm x1
(for connecting HDZero Race VTX)

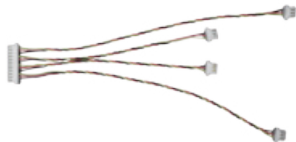

12P Cable x1
(for connecting Champ LED Strip)



M3*6*3.6mm Silicone Grommets (Red) x5
(for installing HDZero VTX)



M3*6*2.6mm Silicone Spacers (Red) x9
(for isolating FC, ESC and VTX)



M3*6*2.3mm Silicone Spacers (Black) x5
(for isolating ESC and frame)



Galvanized Carbon Steel Screws
M3*23.5mm x4



Galvanized Carbon Steel Screws
M3*18mm x4



M3*21mm Aluminum Standoffs x4



M3*5.5*3mm
Aluminum Lock Nuts x4



M3 Hex Nut Driver x1
(for installing Anti-loosening Nuts)



Champ Series Sticker x1



Quick Start Guide x1

5.2 FC Only



Oxbot Champ Racing FC
(MPU6000 Version / ICM42688 Version) x1

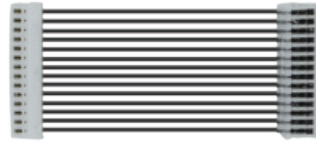

14P Cable 20mm x1
(for connecting FC and ESC)



6P SH1.0 Cable 15mm x1
(for connecting HDZero Race VTX)

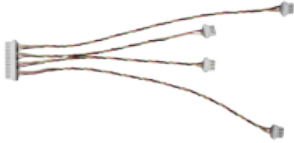

12P Cable x1
(for connecting Champ Racing LED Strip)



M3*6*3.6mm Spare Silicone Grommet (Red)
x1 (for backup in case of FC grommet loss)



M3*6*2.6mm Silicone Spacers
(Red) x5 (for isolating FC and ESC)

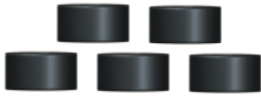

M3*6*2.3mm Silicone Spacers (Black) x5
(for isolating ESC and frame)



Champ Series Sticker x1



Quick Start Guide x1

5.3 ESC Only

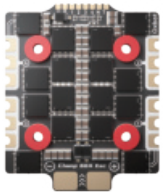

Oxbot Champ 60A OX32
4-in-1 Racing ESC x1

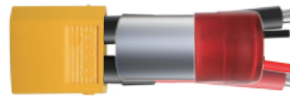

Anti-broken Soft-legged
Capacitor Set x1



Black Heat Shrink Tubes 10mm x2
12AWG Spare Power Cables 70mm x2



14P Cable 20mm x1
(for connecting FC and ESC)



M3*6*3.6mm Silicone Grommet (Red) x1
(for backup in case of ESC grommet loss)



M3*6*2.6mm Silicone Spacers (Red) x5
(for isolating FC and ESC)

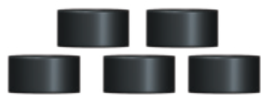

M3*6*2.3mm Silicone Spacers (Black) x5
(for isolating ESC and frame)



Champ Series Sticker x1

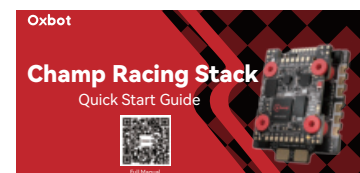

Quick Start Guide x1

Part 2/ Flight Controller

1. Layout

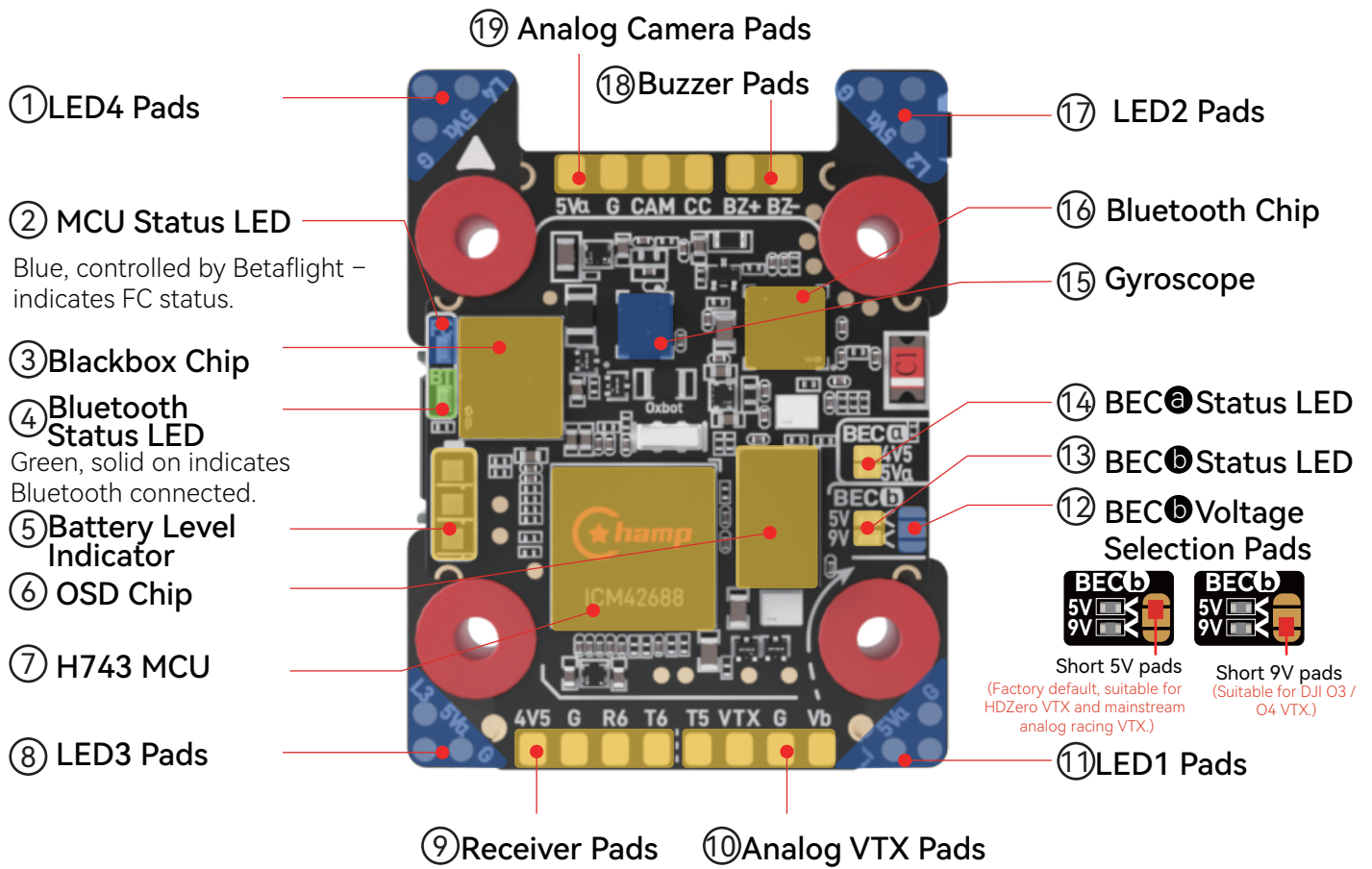

● LED Indicators

② MCU Status LED: **Blue**, controlled by Betaflight; indicates flight controller status.

④ Bluetooth Status LED: **Green**, solid on indicates Bluetooth connected.

⑭ BEC^a Status LED

5Va: **Red** light, solid on = BEC ^a functioning normally.





4V5: **Red** light, solid on = all 4V5 pads on FC are working.

⑬ BEC^b Status LED

5V: **Red** light, solid on = BEC ^b outputting 5V.

9V: **Red** light, solid on = BEC ^b outputting 9V.

● ⑤ Battery Level Indicator

 3 Green LEDs	Voltage Range $\geq 4.1V$	Battery Level $\geq 90\%$
 2 Yellow LEDs	$3.8V \leq$ Voltage Range $< 4.1V$	$40\% \leq$ Battery Level $< 90\%$
 1 Red LED	$3.6V \leq$ Voltage Range $< 3.8V$	$10\% \leq$ Battery Level $< 40\%$
 1 Flashing Red	Voltage Range $< 3.6V$	Battery Level $< 10\%$

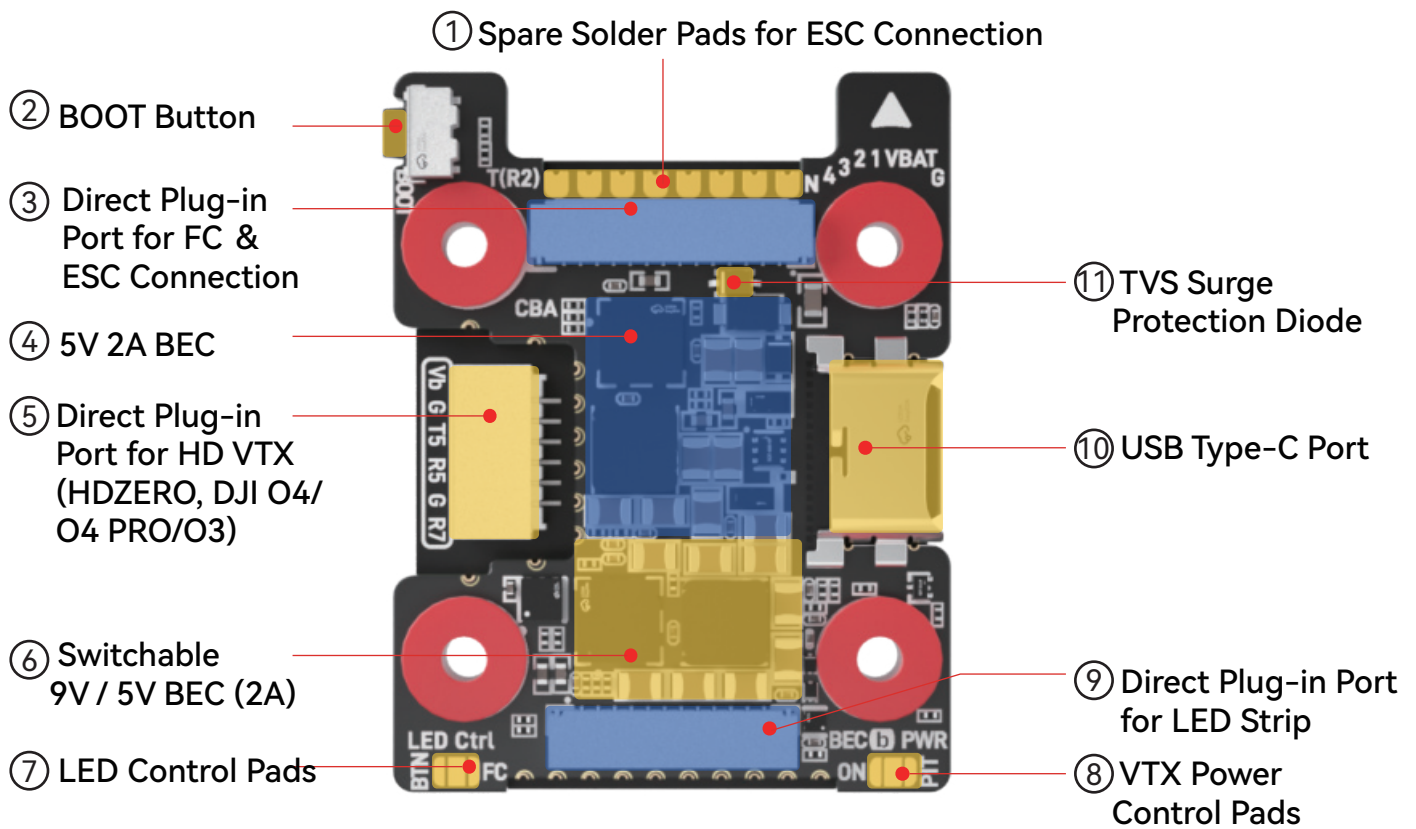

● ② BOOT Button

The BOOT button serves two functions:

1. LED Strip Control

① Double-click: Cycle through colors. The following 6 colors will cycle: Red, Yellow, Blue, Green, Cyan, Magenta.

② Long press for 1 second: Cycle through brightness levels (0-3, where 0 means off). (You can set the LED strip brightness, color, number of LEDs, and meteor effect through the SpeedyBee App).

2. Firmware Flashing

If firmware is corrupted and FC fails to boot:

Via SpeedyBee App:

① Hold BOOT button and power the FC to enter DFU mode.

② Open the SpeedyBee App, navigate to firmware flashing, and follow instructions.

Via Computer:

① Plug USB cable into PC.

② Hold BOOT button, connect USB to FC, then release BOOT.

③ Open Betaflight Configurator on PC and enter firmware flashing page.

● ⑦ LED Control Pads

By default, the LED strip is controlled via the BOOT button. To control it via Betaflight, remove the solder from BTN pads, then solder the FC pad instead. (See: Part 2 > 2. Peripheral Connections > 2.2 Connection Details > 2.2.1 LED Strip > (2) Control Methods)

● ⑧ VTX Power Control Pads

The VTX is powered by BEC ④. By factory default, the left two pads are shorted, which keeps the VTX continuously powered.

To enable VTX power control via your remote controller, remove the solder from the ON pads and short the right two pads (PIT pads). (See: Part 2 > 2. Peripheral Connections > 2.2 Connection Details > 2.2.3 VTX > Power Control Method > Control via Remote Controller Switch)

2. Peripheral Connections

2.1 Connection Overview

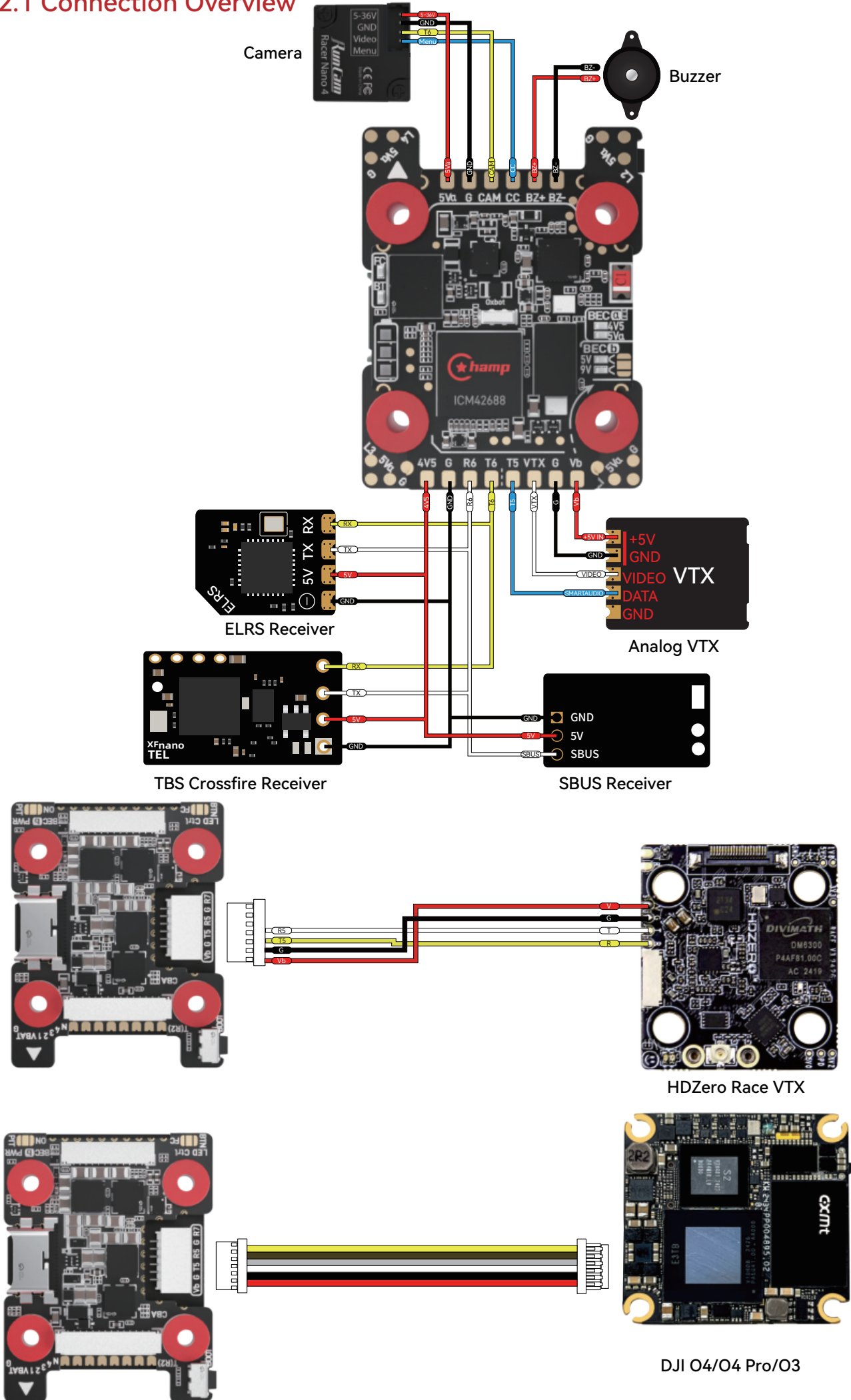

2.2 Connection Details

2.2.1 LED Strip

The LED power circuit includes short-circuit protection. In the event of a crash that damages the LED and causes a short, power will be cut off automatically. The drone will still fly normally after re-arming.

(1) Wiring Guide

- Oxbot Champ Racing LED Strip

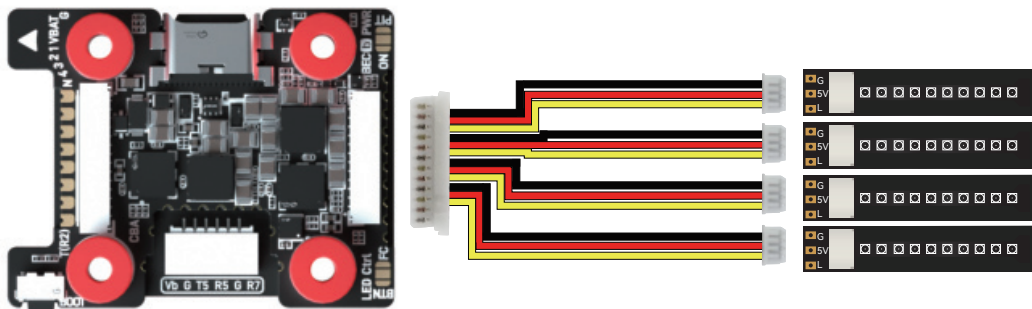

Direct Plug-in

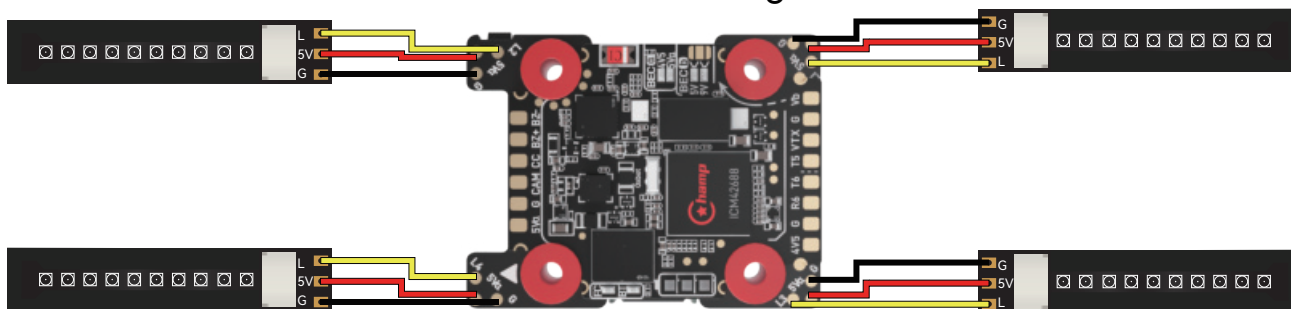

Soldering

*LED strips from other brands can be soldered the same way.

(2) Control Methods

- Control via Button (Default). *Supports up to 18 LEDs per channel.

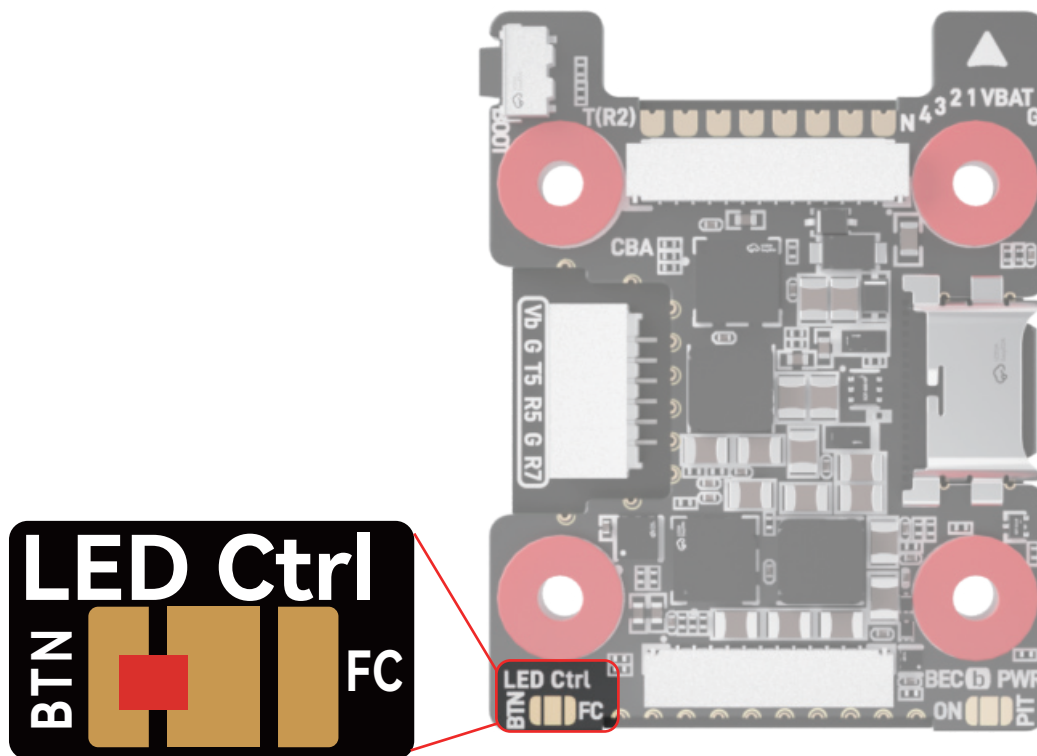

•Control via FC Firmware (Short FC pads).

*BF firmware typically supports up to 32 LEDs per channel.

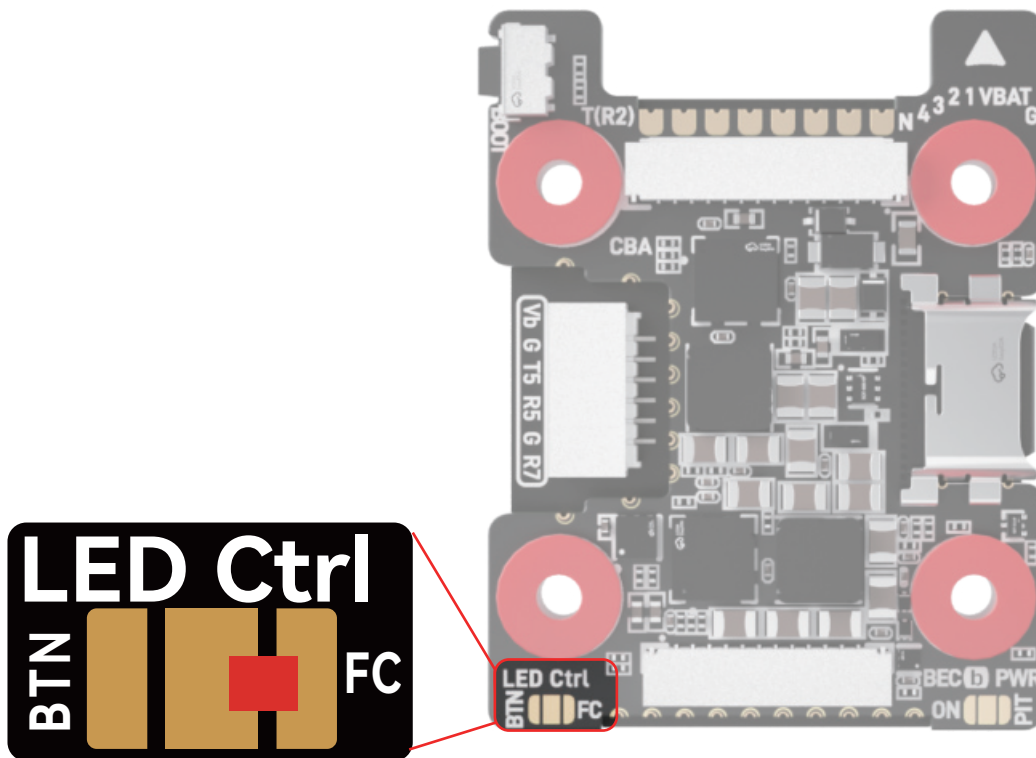

(3) Meteor LED Effect Setup

Step 1:

After connecting the FC, open the SpeedyBee App and tap “Meteor LED Settings” in the Toolbox.

Step 2:

Wait for FC connection. Once connected, the setup page will open automatically.

Step 3:

On the setup page, configure settings as needed: LED control, effect color, number of LEDs, and effect mode.

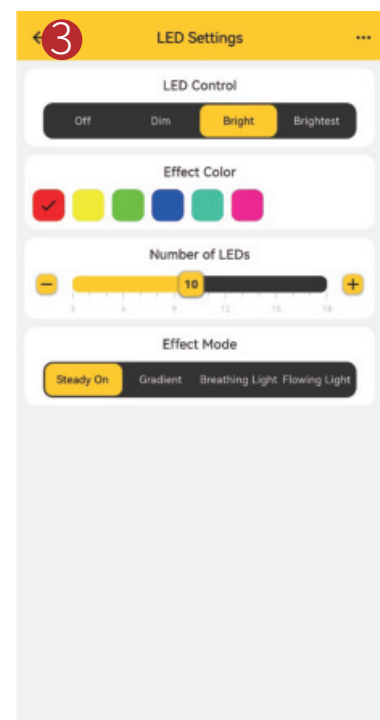
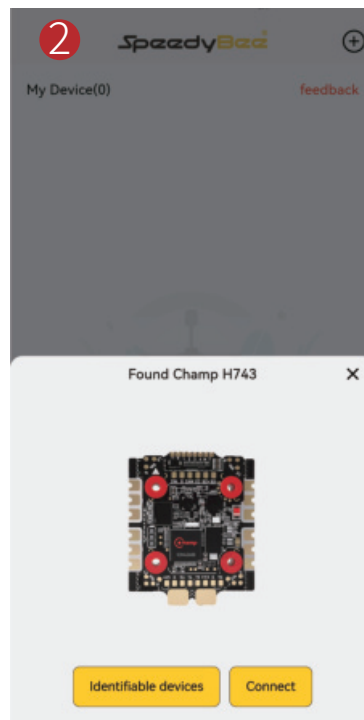
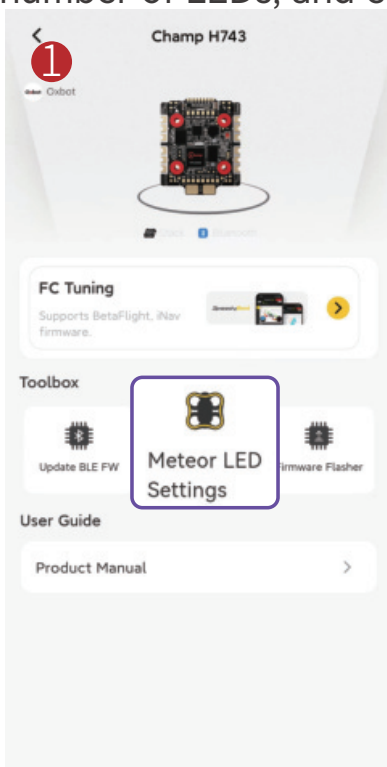

2.2.2 Receiver

(1) ELRS Receiver

•Wiring Guide

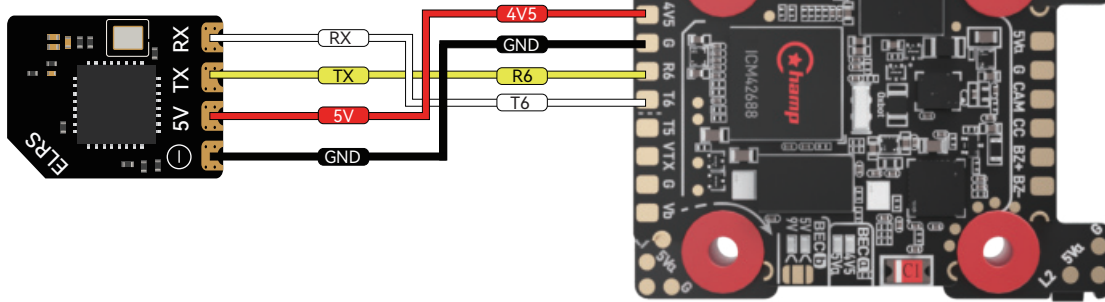

•Configuration Steps

1) In the [Ports] tab, enable serial receiver on **UART6**

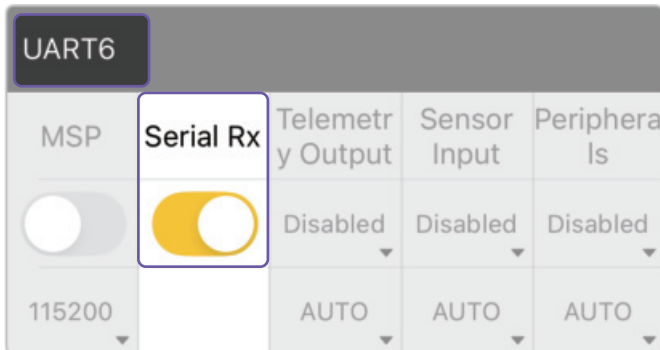

2) In the [Receiver] tab, set the protocol to **CRSF**

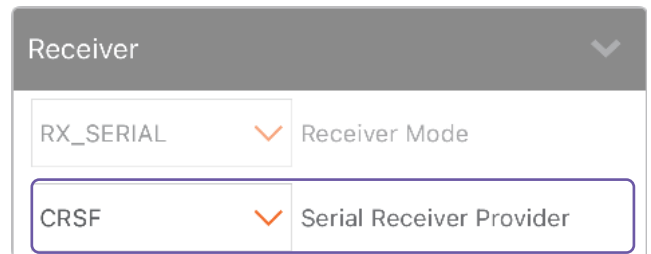

(2) TBS Receiver

•Wiring Guide

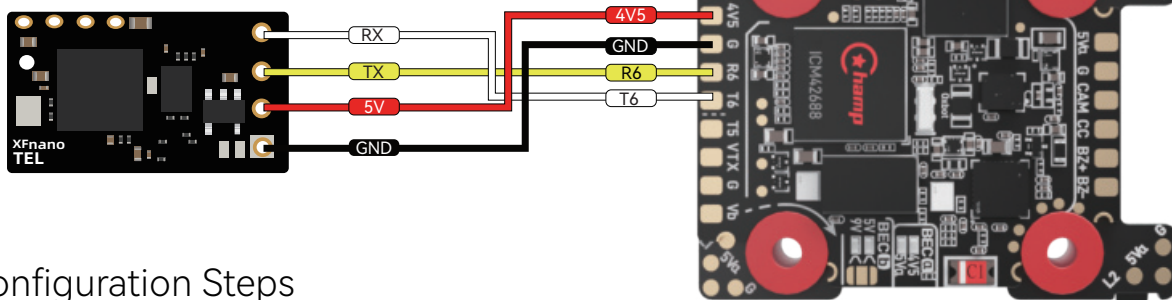

•Configuration Steps

1) In the [Ports] tab, enable serial receiver on **UART6**

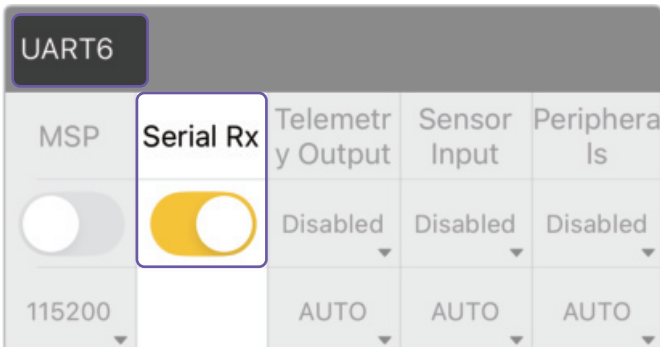

2) In the [Receiver] tab, set the protocol to **CRSF**

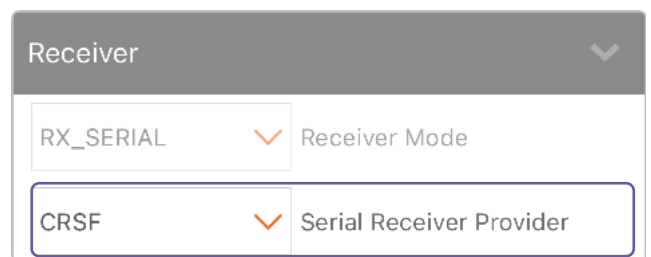

(3) SBUS Receiver

•Wiring Guide

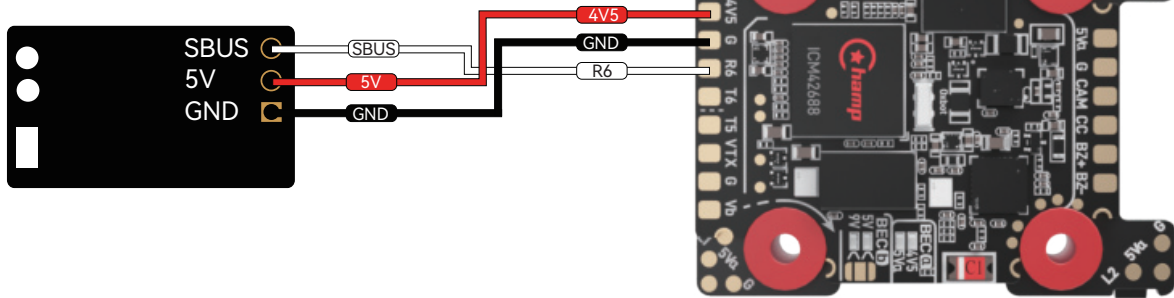

•Configuration Steps

1) In the [Ports] tab, enable serial receiver on **UART6**

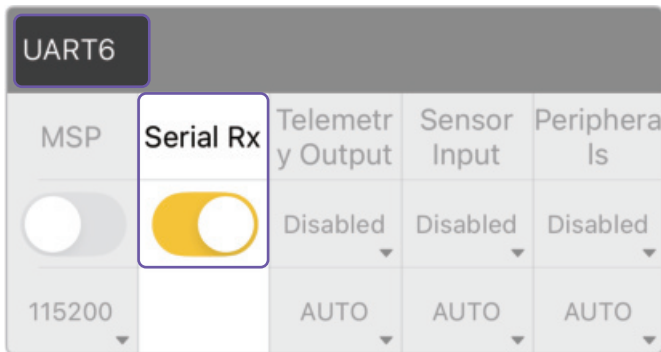

2) In the [Receiver] tab, set the protocol to **SBUS**

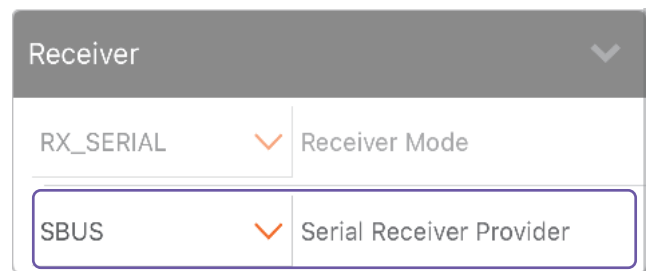

2.2.3 VTX

Voltage Selection

Before use, confirm the VTX voltage input and select 5V or 9V accordingly:

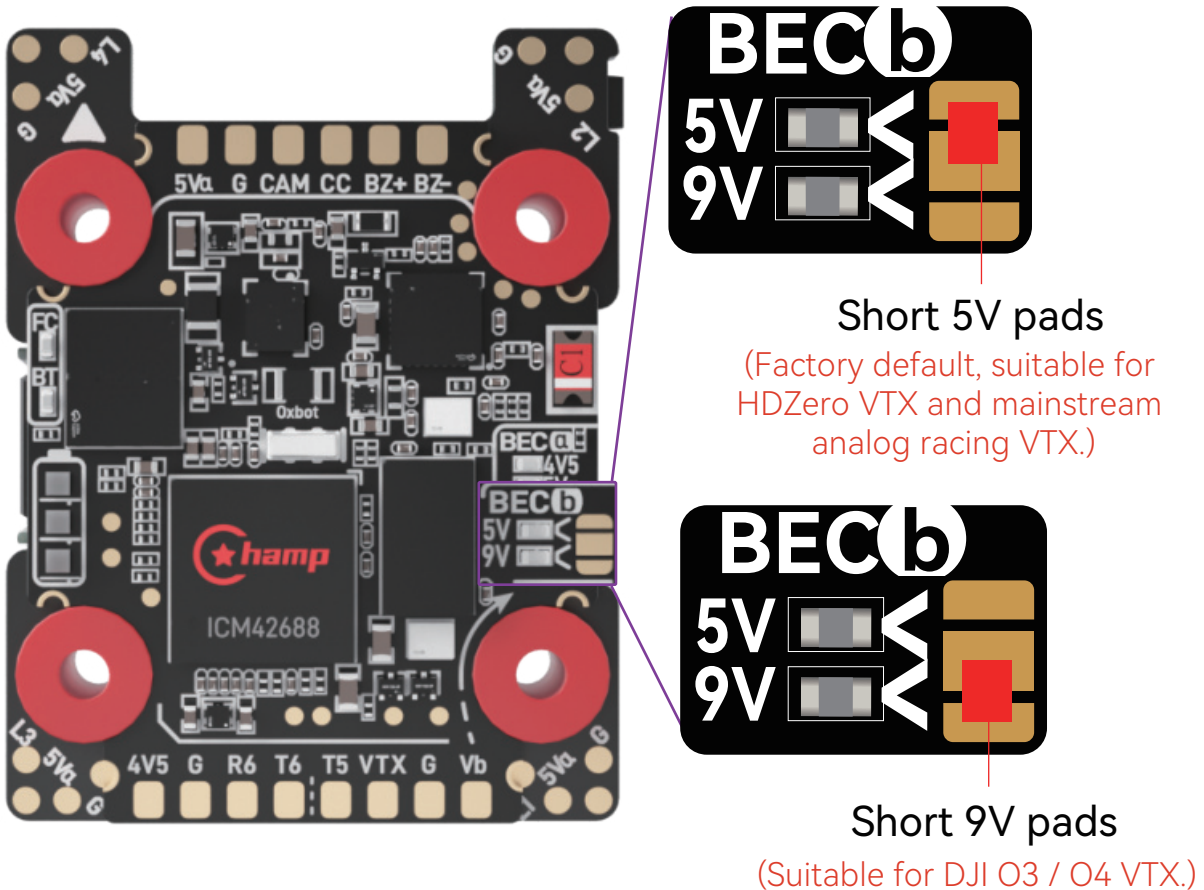

Power Control Methods

- BEC **b** Always On

Factory default. BEC **b** continuously supplies power to the VTX.

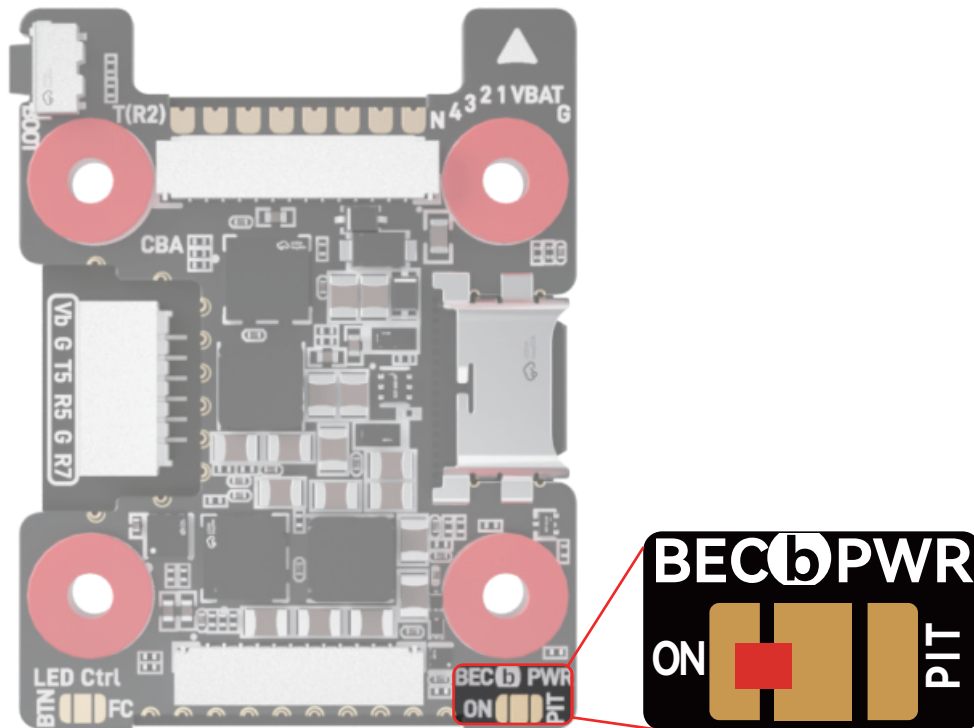

- Control via Remote Controller Switch

Remove solder from the "ON" pads on BEC **b** and short the PIT pads:

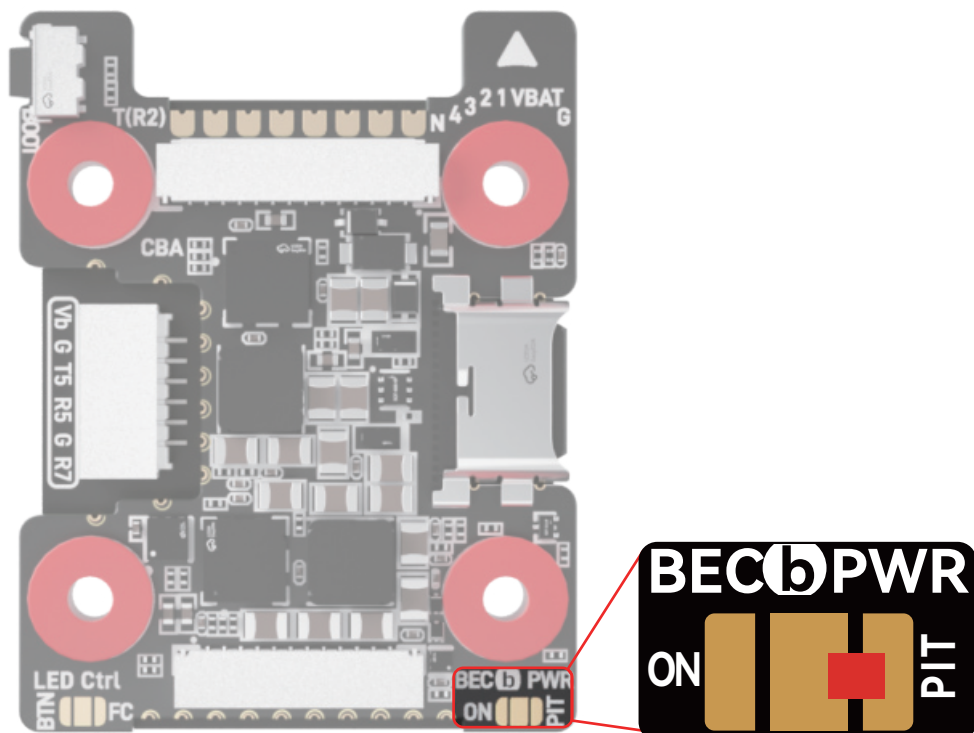

Enable USER1 mode in Betaflight or the SpeedyBee app (see right image).
 When USER1 is Disable, BEC outputs power normally.
 When USER1 is Enable, BEC output is disabled.

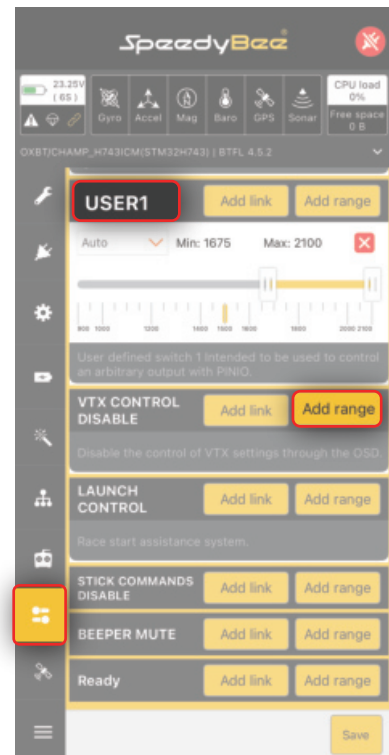

(1) HDZero Race VTX

- Wiring Guide

(1) Using the 6P Cable Provided

Replace the original HDZero VTX cable with the 15mm 6P SH1.0 cable included for a cleaner build. Wiring method as shown:

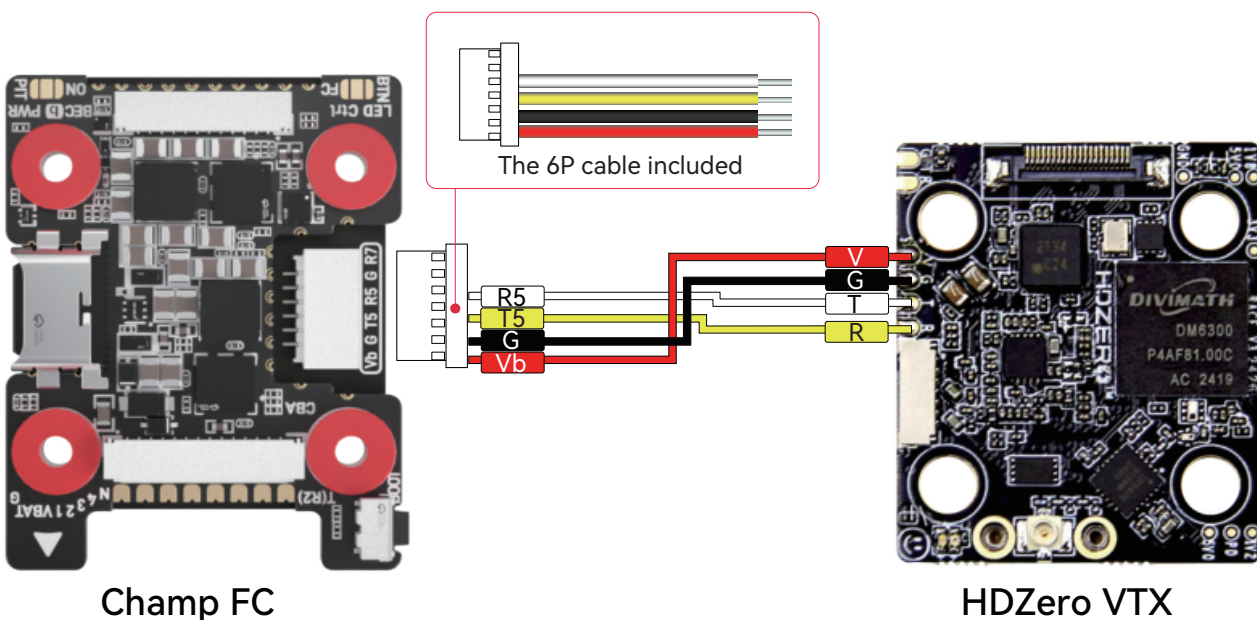

(2) Using the Original HDZero VTX Cable

As HDZero VTX has both new and old versions, if you choose to use the original cable, make sure its wiring sequence is consistent with the one shown in Step (1).
 If the sequence differs, adjust the pins using tweezers to align with the diagram in Step (1).

•Configuration Steps

- 1) In the [Ports] tab, enable MSP and VTX (MSP + Displayport) on UART5

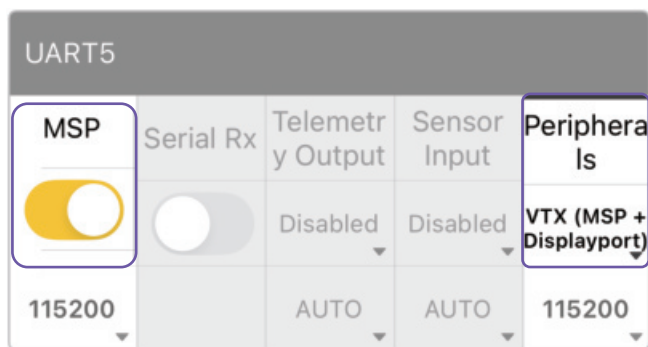

- 2) If your FC firmware is earlier than BF4.3, enter the following commands in the [CLI] tab:

```
set osd_displayport_device = MSP
set vcd_video_system = HD
save
```

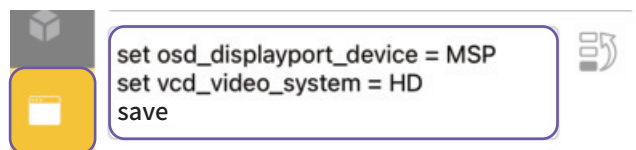

If your firmware is BF4.3 or later, no additional settings are required.

(2) Analog VTX

•Wiring Guide

Before connecting, ensure the correct 5V or 9V pads are shorted according to the VTX voltage requirement.

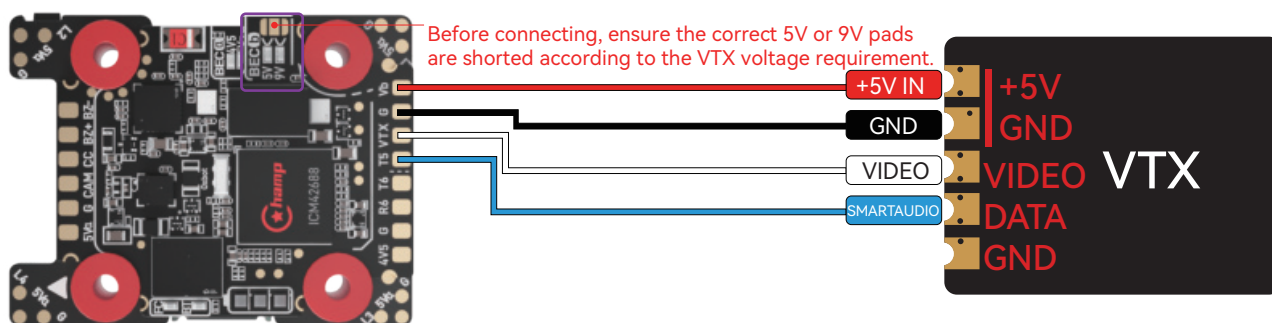

•Configuration Steps

- 1) In the [Ports] tab, enable IRC Tramp or Smart Audio on UART5 (depending on VTX protocol).

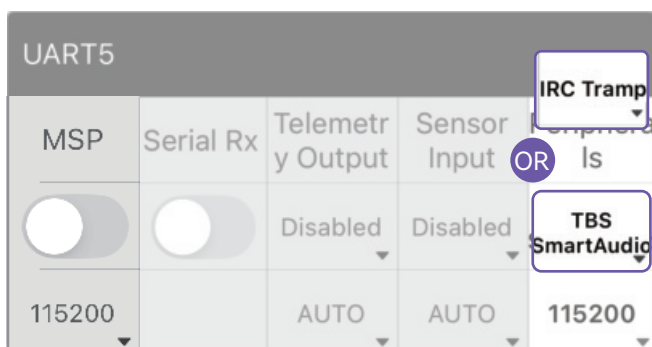

- 2) If your FC firmware is earlier than BF4.3, no CLI commands or video format settings are needed.

If your FC firmware is BF4.3 or later, enter the following in the [CLI] tab:

```
set osd_displayport_device=MAX7456
save
```



- 3) Set AUTO as the video format in the OSD menu.

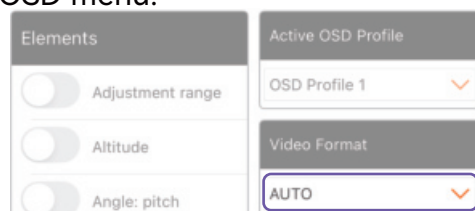

* If OSD fails, manually switch the video format to PAL or NTSC.

(3) DJI VTX

DJI O4 Air Unit

•Wiring Guide

Remove the solder of the 5V pads on the FC, then short the 9V pads instead. After that, connect the DJI-provided 6-pin cable directly to the FC.

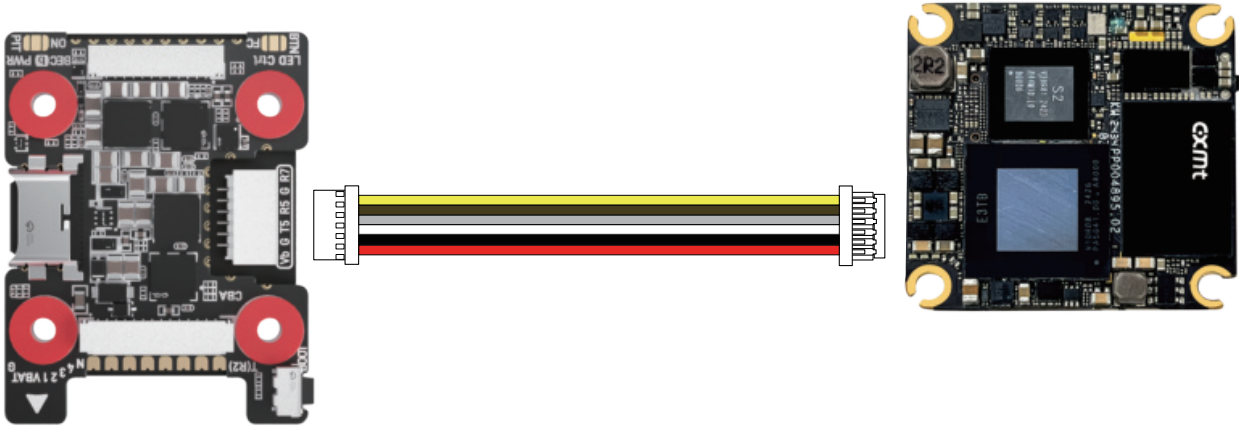

•Configuration Steps

1) In the Ports tab, enable MSP and VTX (MSP+Displayport) on UART5.

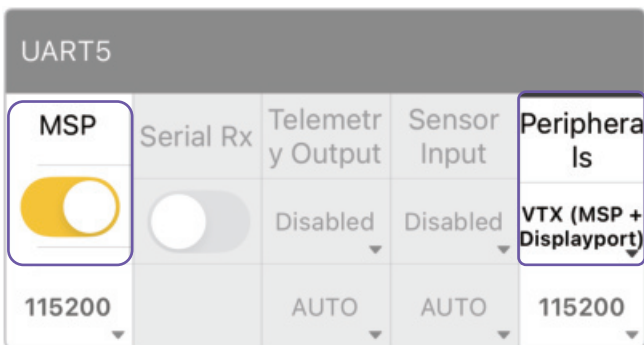

2) If your FC firmware is earlier than BF4.3, enter the following in the CLI:
set osd_displayport_device = MSP
set vcd_video_system = HD
save

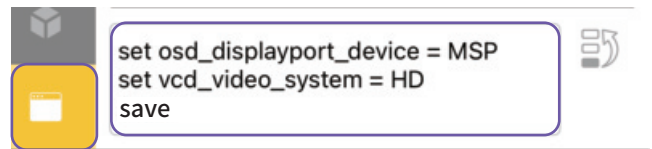

If your FC firmware is BF4.3 or later, no CLI commands are needed.

DJI O3 Air Unit

•Wiring Guide

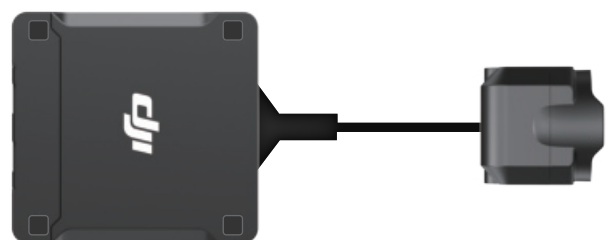
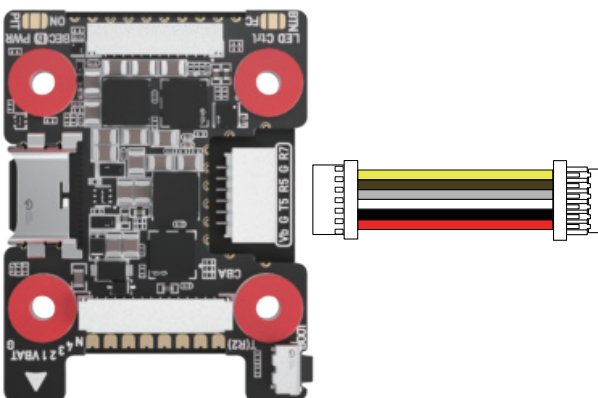

•Configuration Steps

1) In the Ports tab, enable MSP and VTX (MSP+Displayport) on UART5.

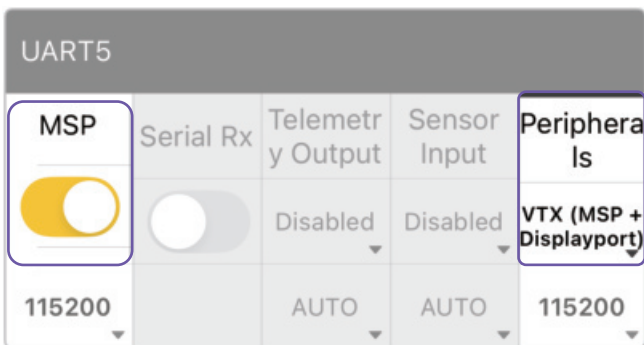

2) If your FC firmware is earlier than BF4.3, enter the following in the CLI:
 set osd_displayport_device = MSP
 set vcd_video_system = HD
 save

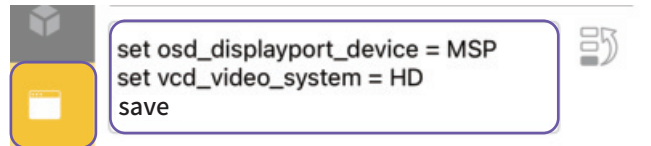

If your FC firmware is BF4.3 or later, no CLI commands are needed.

DJI Air Unit

•Wiring Guide

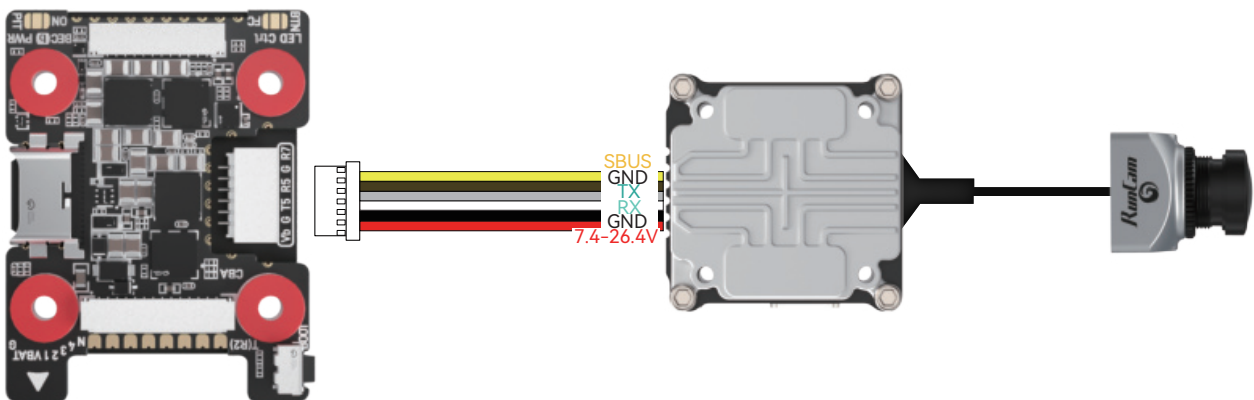

•Configuration Steps

1) In the Ports tab, enable MSP and VTX (MSP+Displayport) on UART5.

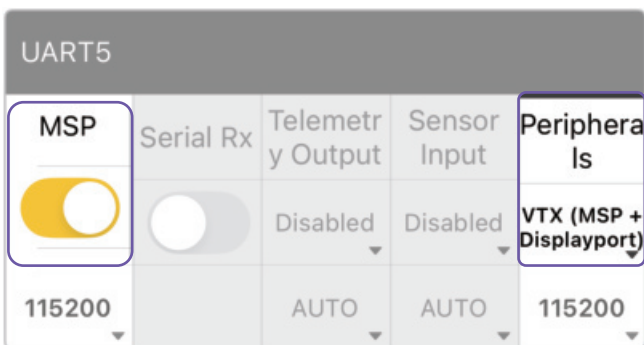

2) If your FC firmware is earlier than BF4.3, enter the following in the CLI:
 set osd_displayport_device = MSP
 set vcd_video_system = HD
 save

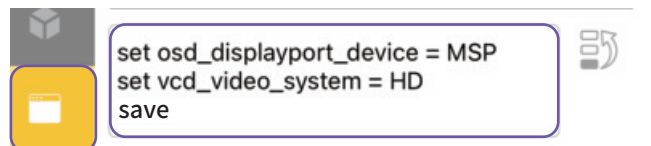

If your FC firmware is BF4.3 or later, no CLI commands are needed.

4. Firmware Update



Step 1: Power on the FC.
Open the SpeedyBee App,
tap the "+" to connect to the FC.

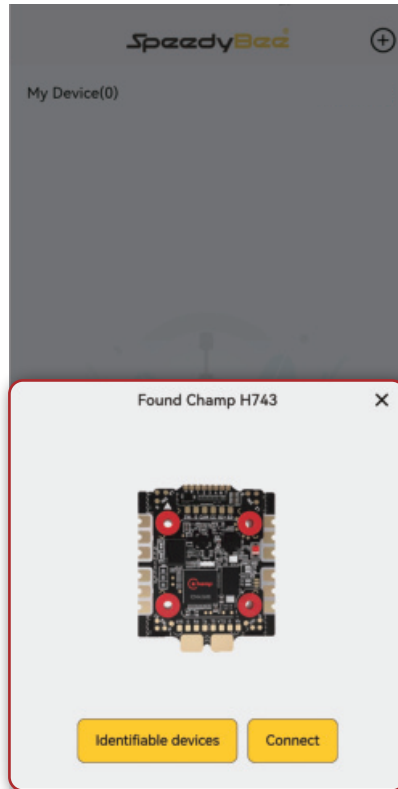

Step 2:
Wait for a successful connection.

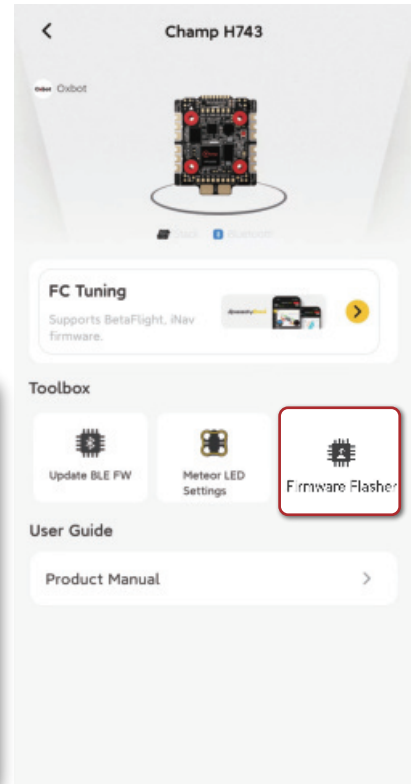

Step 3:
Tap "Firmware Flasher".

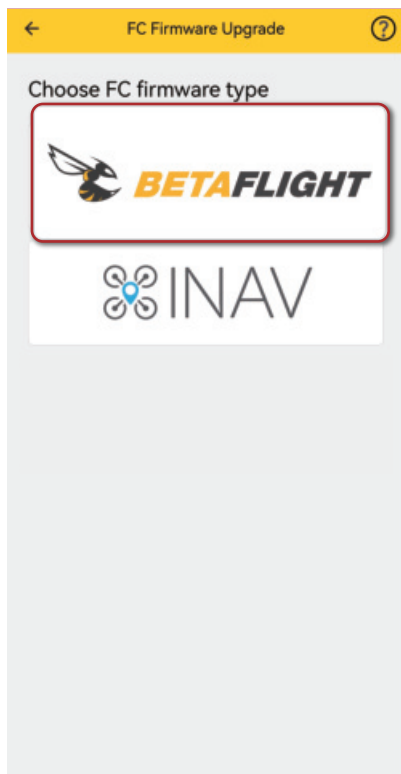

Step 4:
Select firmware type: BETAFLIGHT

Next steps vary depending on your phone system:

● iOS Version

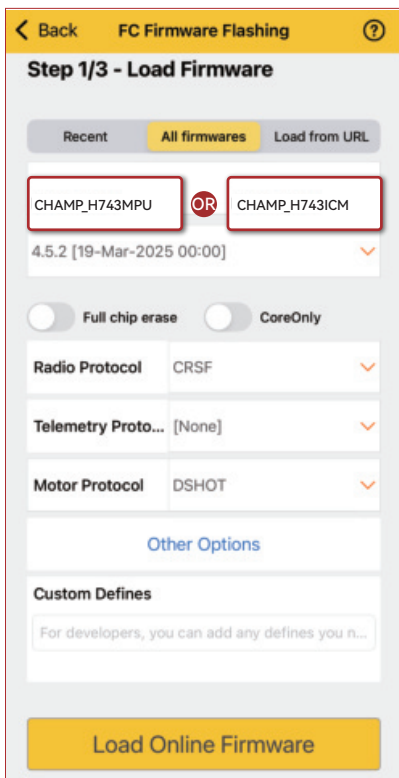

Step 5:

Choose the firmware version:
 CHAMP_H743MPU (MPU6000 version)
 or
 CHAMP_H743ICM (ICM42688 version)

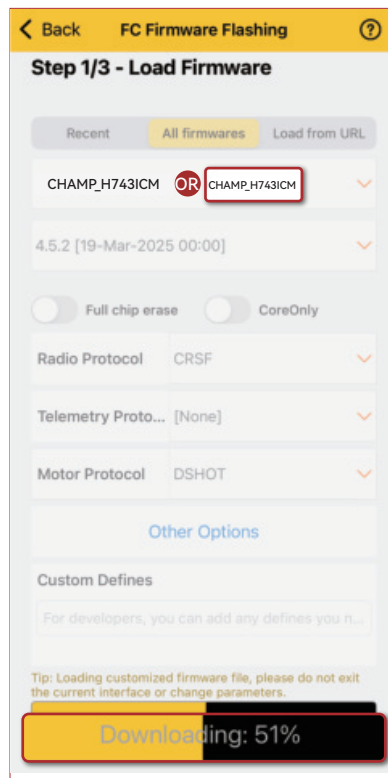

Step 6:

Wait for firmware download to complete.

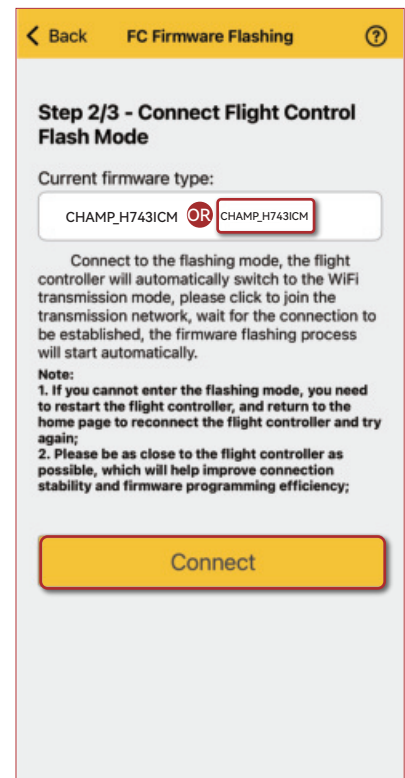

Step 7:

Once downloaded, tap "Connect".

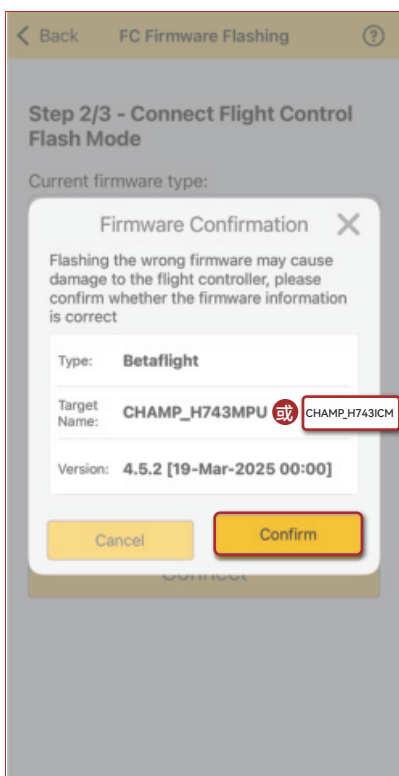

Step 8:

Confirm firmware information, then tap "Confirm".

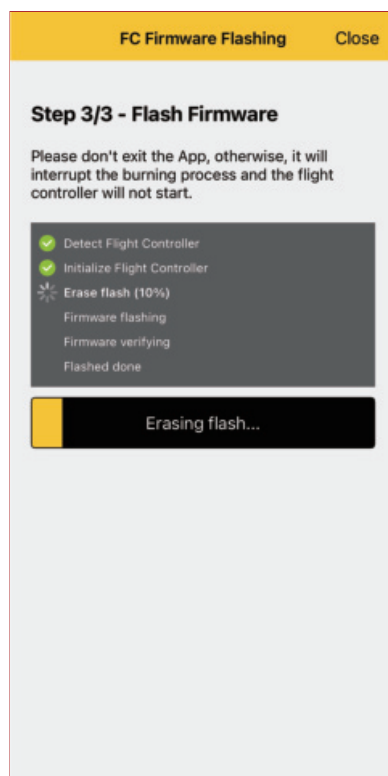

Step 9:

Wait for firmware erasing to complete.

● Android Version

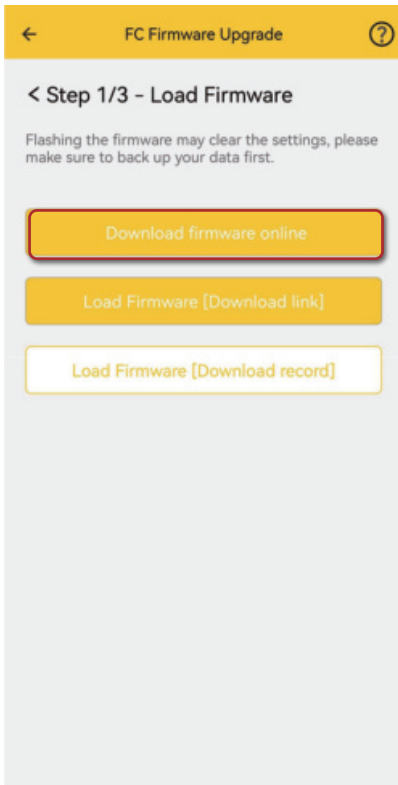

Step 5:
Tap "Download
Firmware Online".

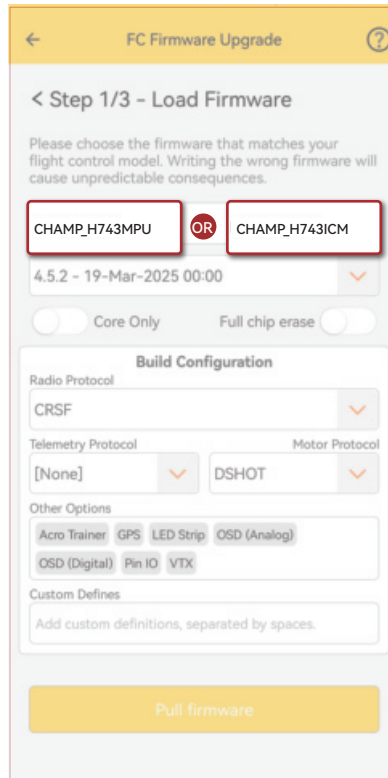

Step 6:
Choose firmware version:
CHAMP_H743MPU (MPU6000 version)
or
CHAMP_H743ICM (ICM42688 version)

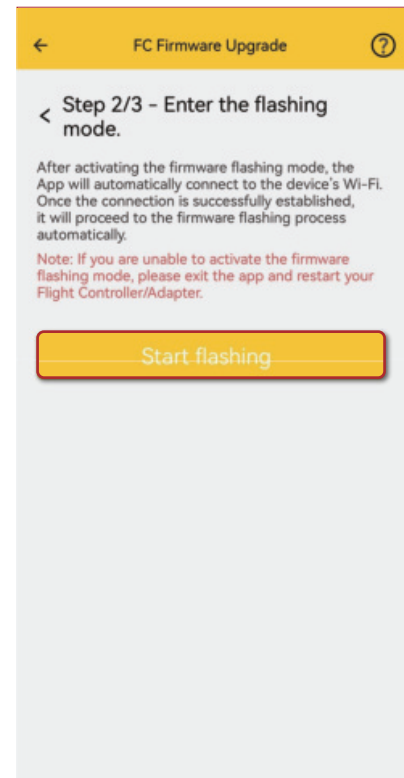

Step 7:
Tap "Start Flashing".

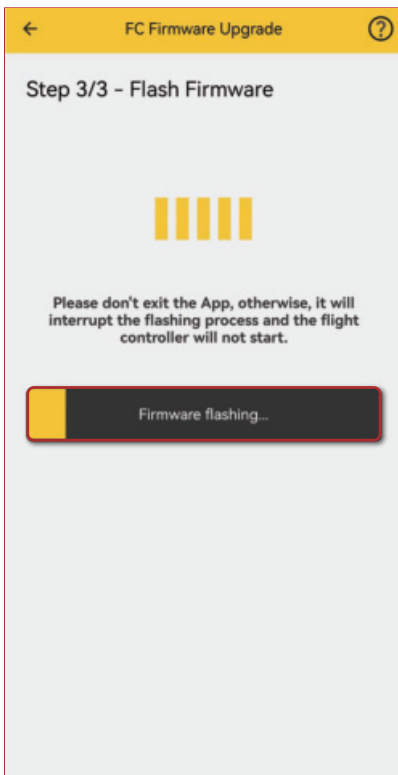

Step 8:
Wait for the firmware
flashing to complete.

5. Specifications

Product Name	Oxbot Champ Racing Flight Controller
MCU	STM32H743
Gyroscope	MPU6000 version / ICM42688 version
Full Manual	https://oxbot.com/download-oxbot-champ-racings-stack/
USB Port Type	Type-C
Barometer	None
OSD Chip	AT7456E
BLE Bluetooth	Supported (Used with SpeedyBee App for FC configuration. Ensure UART1 MSP is enabled and baud rate is set to 115200, or Bluetooth won't work.)
WiFi	Not Supported
DJI HD Video Compatibility	6p plug direct connection. Fully compatible with DJI O4 / DJI O3 / RunCam Link / Caddx Vista / DJI Air Unit. No wiring changes needed.
HDZero Video Compatibility	6p plug direct connection. Note the different pinouts of old and new HDZero versions (see: Part 2 > 2. Peripheral Connections > 2.2 Connection Details > 2.2.3 VTX > (1) HDZero VTX).
Blackbox	16 MB onboard chip
Current Sensor	None
Input Voltage	3~8S
BEC [Ⓐ] Output	5V 2A
BEC [Ⓑ] Output	Switchable: 5V 2A / 9V 2A
4.5V Output	Supported
ESC Signal Pads	M1-M4
Available UART Ports	UART5, UART6, UART7
ESC Telemetry UART	UART2

Betaflight Camera Control Pad (CC)	Supported
GPS Pad	Not Supported
I2C	Not Supported
LED Pads	Supported, 4 channels in parallel
Buzzer Pad	Supported, for 5V active buzzers
PIT Mode	Supported (Short BEC [®] 's PIT pad to enable. (See: Part 2 > 2. Peripheral Connections > 2.2 Connection Details > 2.2.3 VTX > Power Control Methods > Control via Remote Controller Switch)
BOOT Button	Supported. Hold BOOT while powering on to enter DFU mode for firmware flashing when FC issues occur. Also used for LED strip control. (See: Part 1 > Layout > BOOT button)
Supported Firmware	BetaFlight (Factory Default)
Firmware Name	CHAMP_H743MPU (MPU6000 Version) / CHAMP_H743ICM (ICM42688 Version)
Mounting Holes	20 x 20mm (M3)
Dimensions	34.9mm (L) x 27mm (W) x 5.1mm (H)
Weight	6.7g

Part 3/ESC

1. Layout

Spare Pads
for Connecting to FC

Motor 4
Solder Pads

Motor 3
Solder Pads

TVS Surge
Protection Diode

BAT-

BAT+

Motor 2
Solder Pads

Motor 1
Solder Pads

14P Connector
(for direct plug-in to FC)

Driver Chips

MCU Chips

Driver Chips

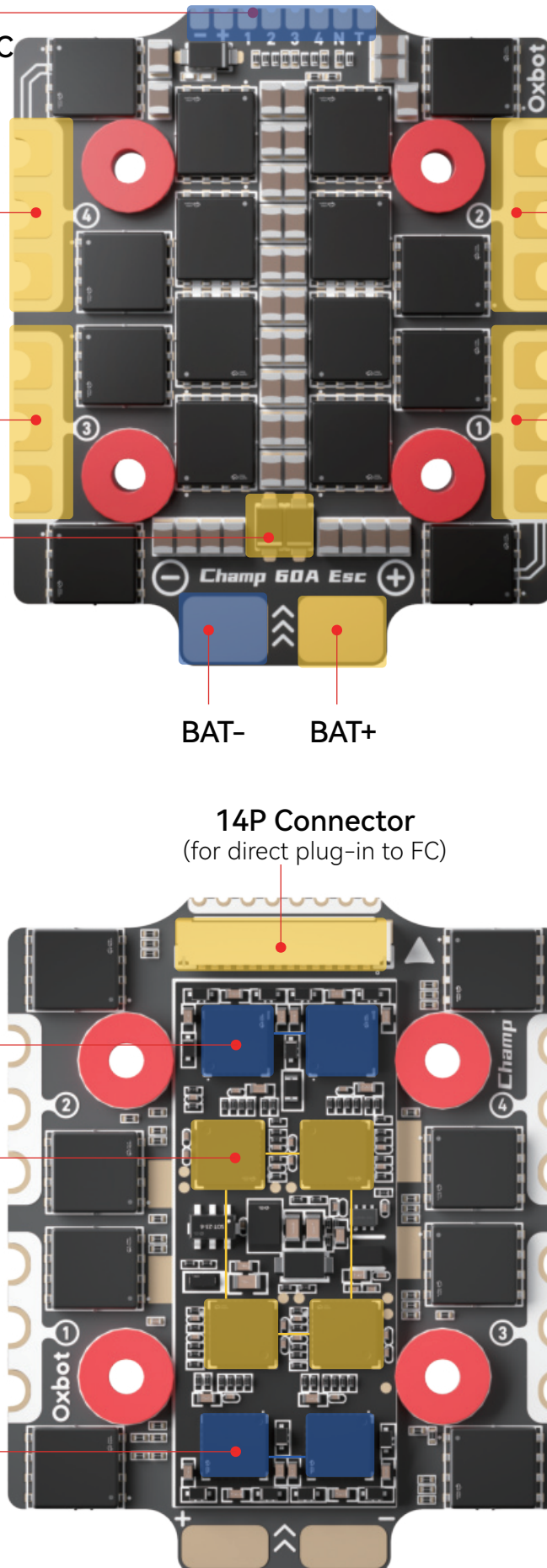

2. FC & Motor Connection

⚠ To prevent the ESC from being damaged by voltage spikes when powered on, please make sure to use the solid-state capacitor. A capacitor is included in the Stack and single ESC packages.

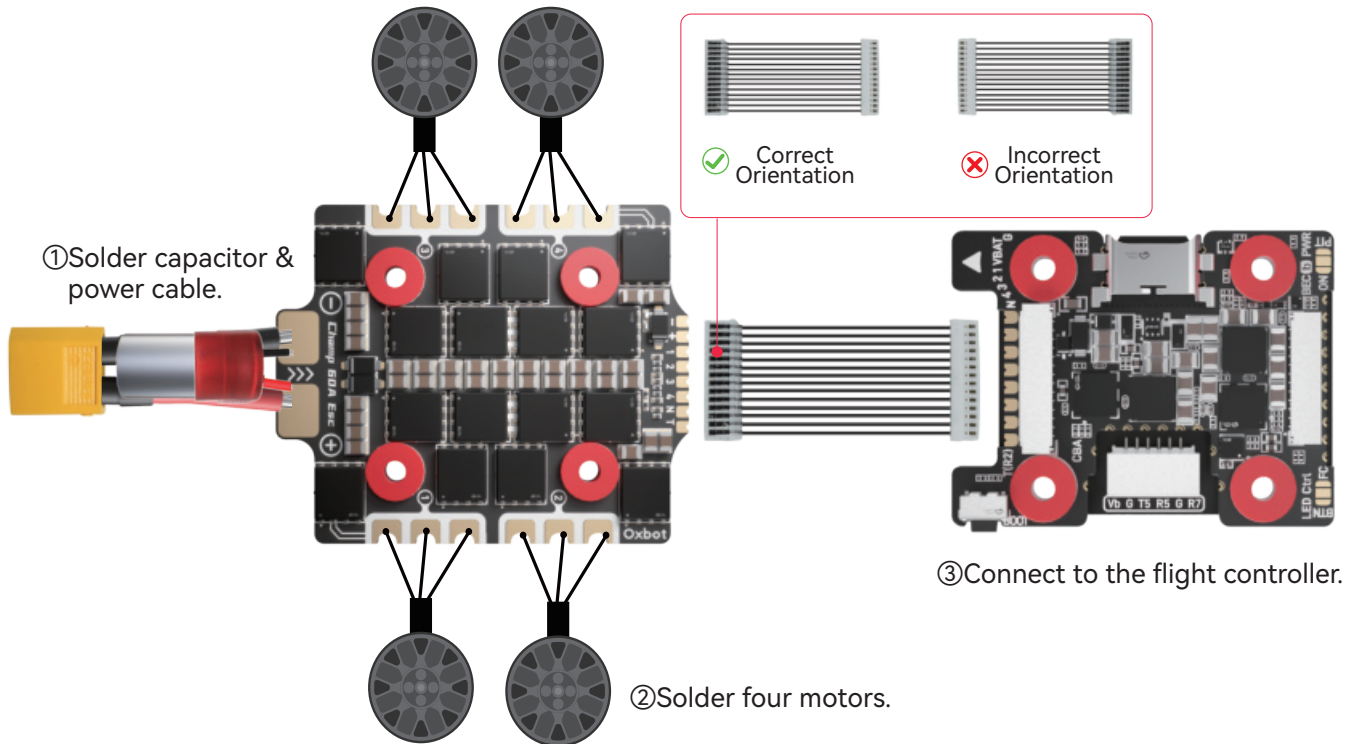

ESC and FC can also be connected by soldering wires. Pad definitions are shown in the diagram below:



Oxbot Champ 60A OX32
4-in-1 Racing ESC

Oxbot Champ Racing FC

3. Configuration Instructions

3.1 Connect to Ground Station and Configure

- (1) Remove all propellers.
- (2) Power the drone with a battery and connect the FC to the computer using a data cable.
- (3) Open the OX32 ESC firmware ground station: <https://ox32.oxbot.com>, then click [Connect Device]



- (4) After successful connection, enter the configuration interface and adjust parameters as needed.

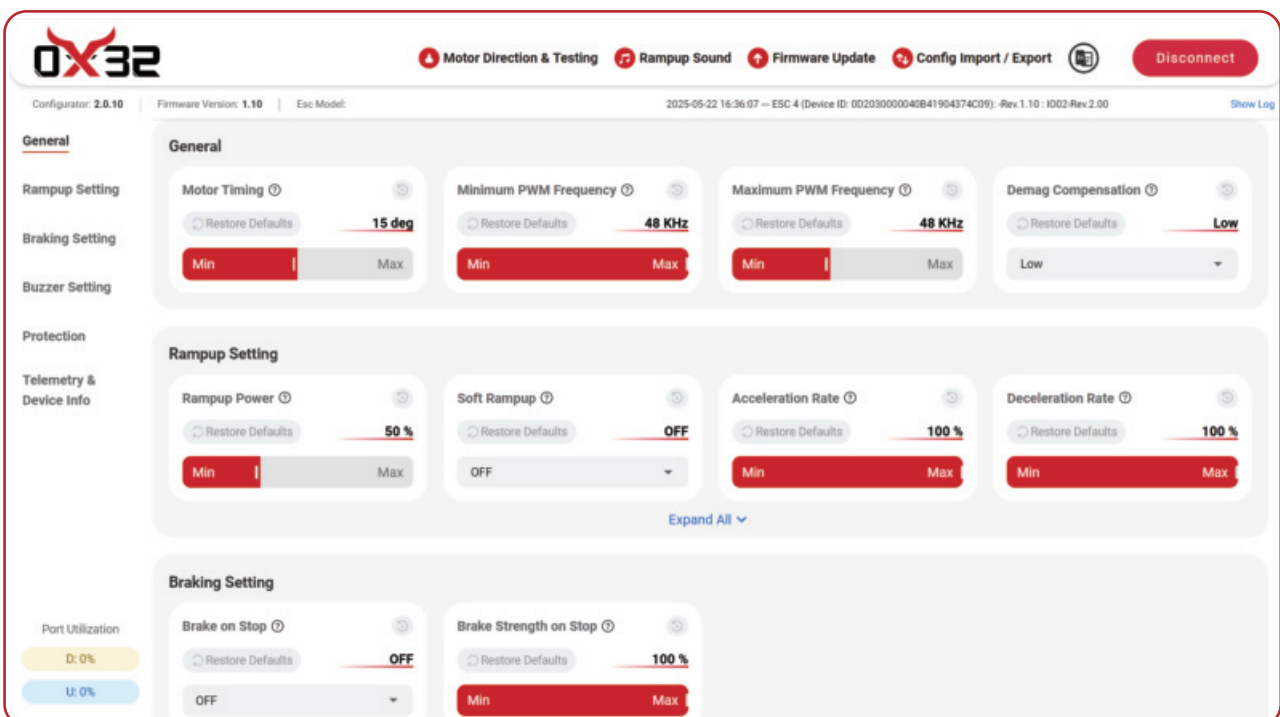

3.2 ESC Firmware Update

After successfully connecting to the ground station, click [Firmware Update] to update the ESC firmware.

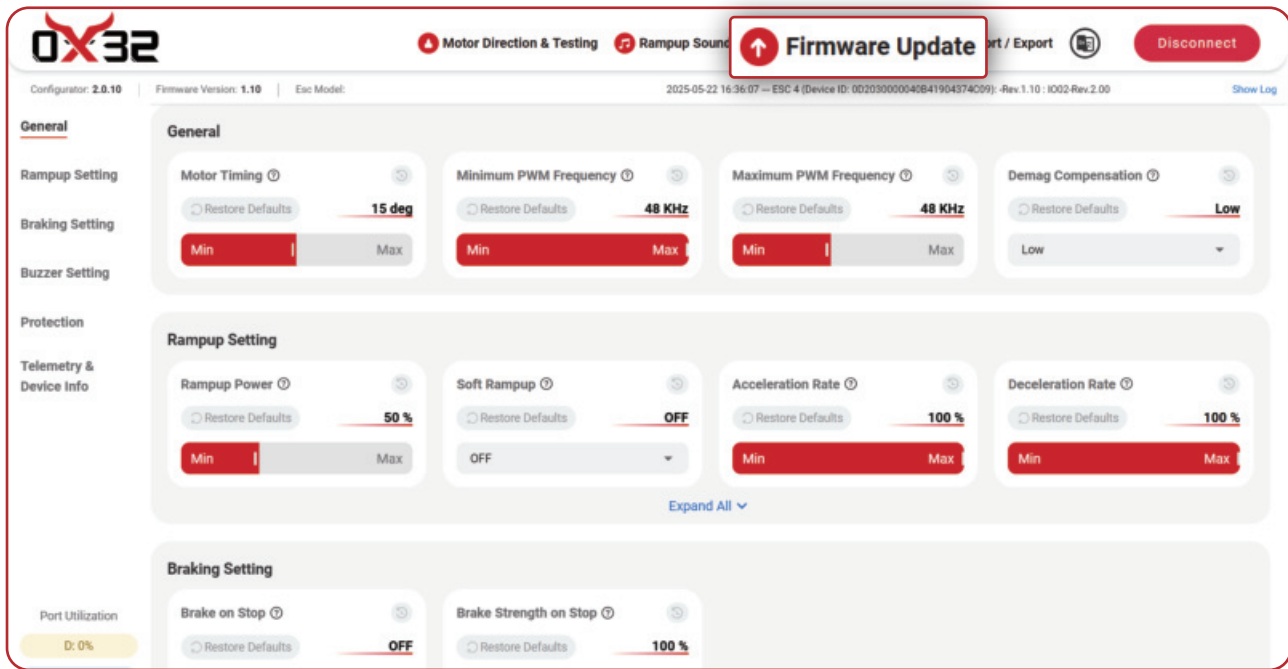

4. Specifications

Product Name	Oxbot Champ 60A 4-in-1 Racing ESC
Firmware	OX32 Firmware
PC Ground Station	https://ox32.oxbot.com/
Full Manual Link	https://oxbot.com/download-oxbot-champ-racings-stack/
Continuous Current	60A per channel
Peak Current	80A per channel (10 seconds)
Max Current on a Single Channel (only one motor running)	110A (10 seconds)
Built-in TVS Surge Protection Diode	Yes
External Capacitor	1000uF solid-state capacitor (included in package)
ESC/Motor Protocols	DSHOT300/600
Input Voltage	3–8S Lipo battery
Output Voltage	VBAT
Current Sensor	Not Supported
ESC Telemetry	Supported
Mounting Hole Pattern	20 x 20mm(M3)
Dimensions	42.7 (L) x 35 (W) x 4.7 (H) mm
Weight	14.6g